

RHINO SOLAR 3HP IGBT BASE AC & DC VFD DESIGNED & MANUFACTURED IN INDIA

60V to 450V 13Amp DC/220V AC



RMCS – 2330

Operaing Manual v1.0

Rhino Motion Controls

Contents

Introduction And Features	3
Wiring Diagram And Pinouts	4
Motor And Power Connection	5
Display And Buttons	6
Drive Parameters	8
State Functions	10
Last Error Value	11

Rhino Motion Controls

Introduction

- This **solar pump controller** continuously monitors system performance and detects a variety of abnormal conditions.
- In many cases, the controller will compensate as needed to maintain continuous system operation. However, if there is a high risk of equipment damage, the controller will protect the system and display the fault condition.
- The **solar pump controller** is a variable-speed motor drive designed to operate various **BLDC pump sets**, specifically engineered for **1HP To 3 HP Pumps**. The **RHINO SOLAR PUMP VFD** is designed to deliver water in remote locations where access to reliable AC power may be uncertain or non-existent. It is suitable for all locations and operates seamlessly on both

DC and AC power.

- This series of **AC and DC motor drives** has abundant features, including a multi-function I/O terminal, **V/f control**, and **auto-torque, auto-slip compensation**, and a built-in digital keypad that can be connected to the VFD with an extended wire. During sunny days, the solar pumping system can consistently and efficiently move water. In instances where there are no batteries or other energy storage devices, it is advisable to pump water to a reservoir for future use. Water sources can range from natural bodies like rivers, lakes, and wells to specialized waterways. To manage the pump's operation effectively, a **float switch** can be installed in the water tower.
- This **three-phase solar pump drive** continuously monitors system performance and detects a variety of abnormal conditions. In many cases, the controller will compensate as needed to maintain continuous system operation. However, if there is a high risk of equipment damage, the controller will protect the system and display the fault condition.
- The **solar pump controller** is a variable-speed motor drive designed to operate various **AC Induction Pump Sets** specifically engineered for **3HP Pumps**.

Features:

- It operates 2 Types Of Motors a **1. 3- Phase AC induction Motor, 2. 3-Phase PMSM (BLDC) Motor.**
- It can accept **DC power ranging from 60 Vdc to 450 Vdc**, and for **AC power**, it can also directly take **220 Vac**.
- Continuous and highly efficient **MPPT Power Tracking at 99%**.
- Ideal for **1HP to 3HP AC Induction Motors** and **BLDC Motors**.
- Rated to handle up to **2.8 kW** input DC power with **13 amps** of continuous input current.
- Operating flawlessly within an **ambient temperature range of 0 to 90 degrees Celsius**.
- Switching from **DC to AC** with the single switch provided in the VFD.
- This system prioritizes safety with built-in features such as **reverse polarity protection, over-temperature safeguards, under-voltage protection, and overload protection**.
- **Float sensor inputs** can be connected to control the water level in a fixed tank system. In case a float sensor is not intended to be used, please hook up a **short circuit wire** between **OV/reference** and **TL input**.

Rhino Motion Controls

Wiring Diagram and Pinout of the Drive:

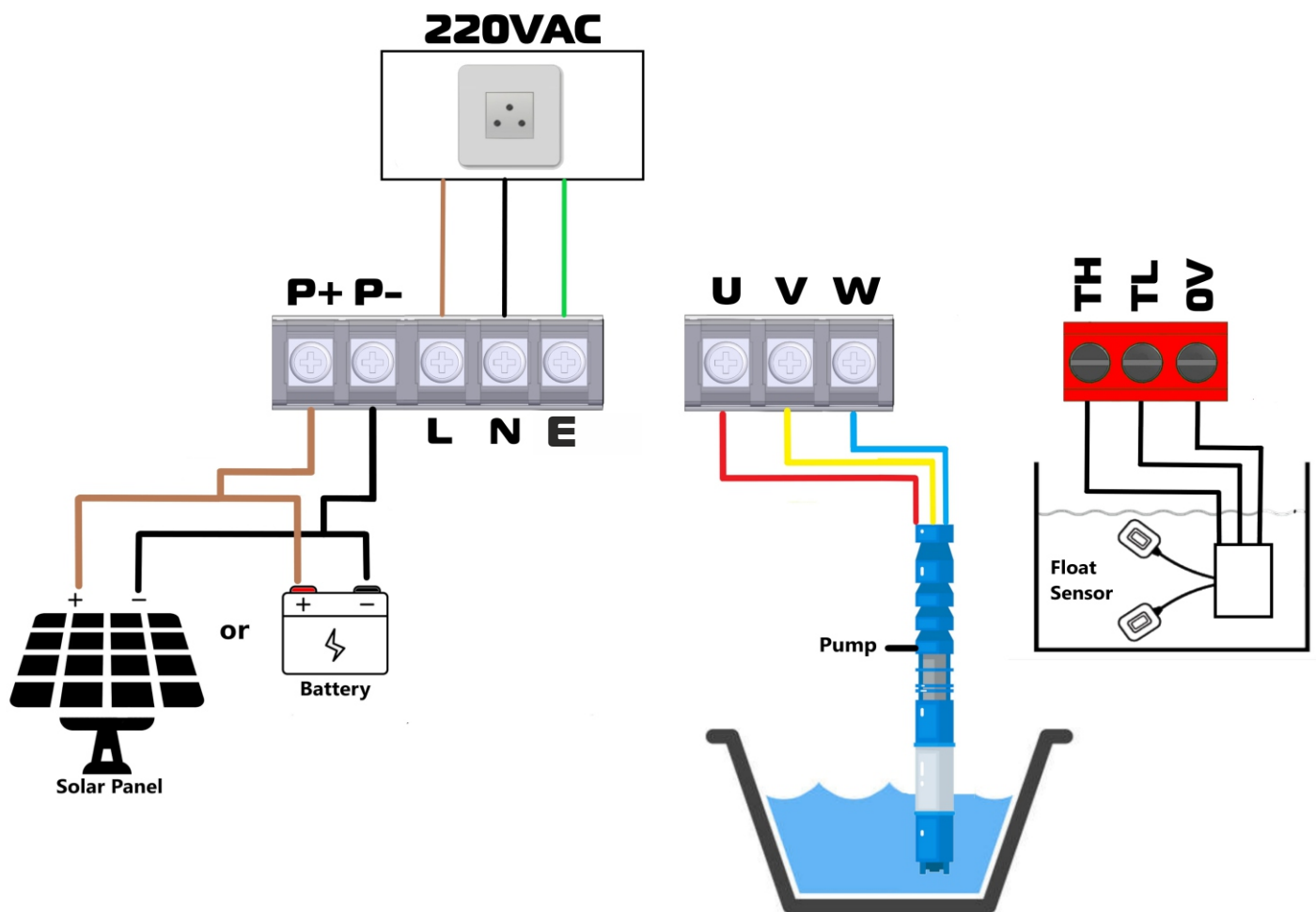

Fig 1:

Rhino Motion Controls

Motor and Power connection:

Terminal Name	Description
P+	Positive DC Input from Panel (MC4 Connector)
P-	Negative DC Input from Panel (MC4 Connector)
U	Motor phase 1 (Red)
V	Motor phase 2 (Yellow)
W	Motor phase 3 (Blue)
AC	Input P (Brown)
AC	Input N (Black)
AC	Earthing (Green)

As per the **fig 1**. The VFD controller have following connections. The P+ and P- are the power input which needs to be connected with either the battery or the solar power output.

In case the solar power is not available, you can directly connect the Drive to normal 220V AC outlet available as given in the image.

A switch is given in the back to turn on or off the AC supply.

U, V and W are the motor phase wires that needs to be connected with respective of the motor's U,V and W terminal.

The other connection are for the float switch if you are using one. The TH and TL are for the input of water level high and low signal.

If you don't want to use the float switch then you can manually turn on and off the VFD controller from the switches. For that you will require to short the TL and OV terminals of the VFD.

Note: If you have connected both AC and DC and the AC switch is on, then the VFD will automatically work with the supply with more power input. So if you want to use DC then simply turn of the switch.

Rhino Motion Controls

Name	Description
TH	Tank High Sensor Input
TL	Tank Low Float Sensor Input
GND	Gnd Reference For Float Sensor

The other connections TH, TL, and OV are for the float switch. TH and TL are for high and low water level input signals. based on which the controller will get on and off. If you want to use the VFD manually, then you can simply short the TL and OV.

Rhino Motion Controls

Motor and Power connection:

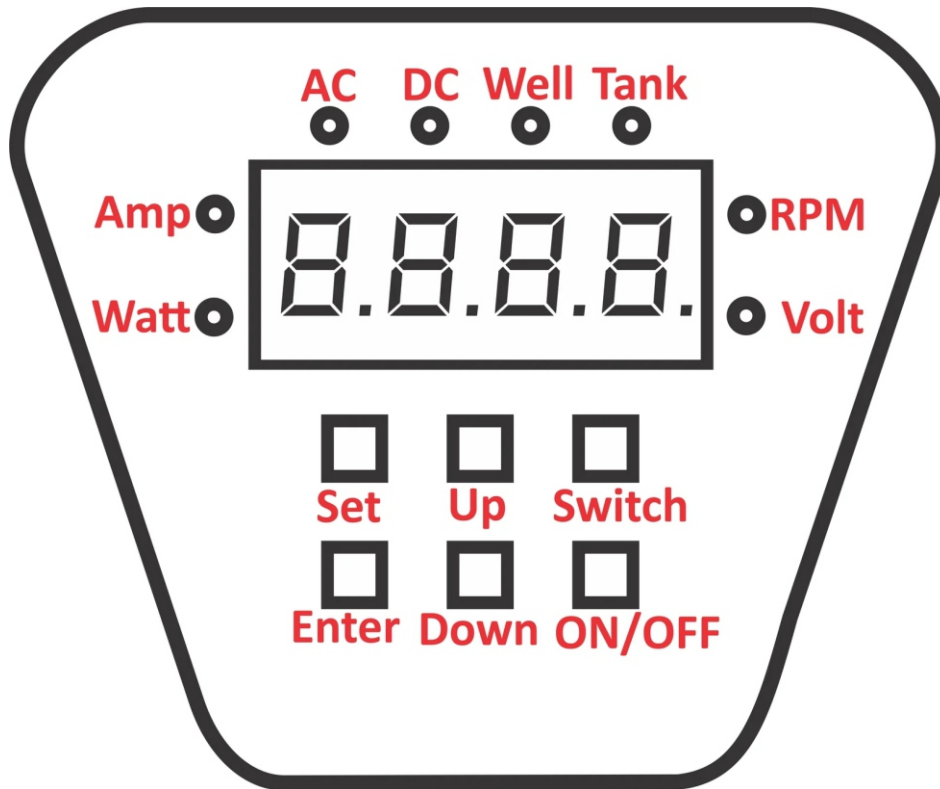

Fig 2:

Button	Description
Set	Saves the parameter to the memory
Enter	Moves to the next parameter
Up	Increases the parameter value
Down	Decreases the parameter value
Switch	Changes the LED segment display parameters as per the above
On/Off	To turn on and off the inverter

Rhino Motion Controls

Name	Description	Unit
Input DC voltage	Shows input voltage	Volt (V)
Motor phase current	Shows input current of the motor	Ampere (A)
Motor running frequency	Show the frequency of the motor	Hertz (Hz)
Motor running power	Show the power required by the motor	Watt (W)
Drive temperature	Show drive's temperature	Celcius (C)

Rhino Motion Controls

Drive Parameters :

Parameter	Name	Description	Default value
P1	MPPT tracking start offset	MPPT tracking start level	4
P2	No load frequency	Frequency at no load error	40
P3	Switchover Frequency level	Frequency at which open loop switched to closed loop	10
P4	Startup torque command	The torque setting for open-loop star up	240
P5	Motor peak current limit	sets the peak current the motor coil	310
P6	Motor Type	Sets the inductance of the motor coil	1
P7	PI loop overall gain	Peak gain setting for the PI loop	515
P8	Hold time for FOC synchronization	Sets the hold time during syncing of the motor from open loop to closed loop	40

Rhino Motion Controls

Drive Parameters :

Parameter	Name	Description	Default value
P9	Torque limit setting	Maximum torque command given to FOC loop	480
P10	V/F motor rated voltage	Voltage at the rated frequency	80
P11	V/F motor rated frequency	The rated frequency of the motor	50
P12	Select closed loop operation type	FOC-0, V/F-1	1

Rhino Motion Controls

State Function:

Note- For this function, the register number. will be fixed at 40002, and the address at1, Lower byte and access will only be read-only.

State	Name	Description
0	MOTOR_STATE_STANDBY	Motor will shut down
1	MOTOR_STATE_STARTUP	Motor will start
2	MOTOR_STATE_SYNCRON	Motor will be in sync
3	MOTOR_STATE_CSLDSPD	Motor will be in closed loop
5	MOTOR_STATE_MPPTRON	Motor will in MPPT mode
4	MOTOR_STATE_SHUTDWN	Motor will shut down
6	MOTOR_STATE_VFCNTRL	Motor will be in V/F mode

Rhino Motion Controls

Error Function:

Note- For this function, the register number. will be fixed at 40002, and the address at1, Lower byte and access will only be read-only.

Error	Name	Description
OFF	ERROR_STATE_NOERROR	Motor is off, no error
LOWP	ERROR_STATE_LOWPWR	Inverter auto shut due to low input power
LOWV	ERROR_STATE_LOWVLT	Inverter auto shut due to low input voltage
MTRJ	ERROR_STATE_MTRJAM	Inverter auto shut due to motor overload
CFL	ERROR_STATE_CFAULT	Inverter Circuit failure due to high current
VFLD	ERROR_STATE_VFAULT	Inverter circuit failure due to high voltage
NLD	ERROR_STATE_NOLOAD	Motor not drawing sufficient power
HEAT	ERROR_STATE_OVHEAT	Inverter auto shut due to over temperature
INEEF	ERROR_STATE_INEFFI	Inverter auto shut due to incorrect operation
LOWS	ERROR_STATE_LOWSTR	Inverter auto shut due to start power
PHS	ERROR_STATE_PHASE	Incorrect motor connections

Rhino Motion Controls

Service and Support

Service and support for this product are available from the Rhino Motion Controls website (<http://www.rhinomc.com>). (www.robokits.co.in) and our customer service email: info@rhinomc.com, support@robokits.co.in **One-Year Warranty against manufacturing defects.**

Rhino Motion Controls (rhinomc.com) warrants its products against defects in materials and workmanship for a period of 1 Year from shipment delivery. During the warranty period, Rhino Motion Controls will either, at its option, repair or replace products which proved to be defective.

Exclusions

The above warranty does not extend to any product damaged by reasons of improper or inadequate handling by the customer. improper or inadequate customer wirings, unauthorized modification or misuse, or operation beyond the electrical specifications of the product and/or operation beyond environmental specifications for the product.

Obtaining Warranty Service

To obtain warranty service, please contact our customer service department at info@rhinomc.com or support@robokits.co.in. before returning the product for service. Please make sure that you have gone through this entire installation manual and datasheet. Before deciding that your product is liable for replacement or repair under this 1-year warranty, the customer shall prepay shipping charges for products returned to Rhino Motion Controls for warranty service, and Rhino Motion Controls shall pay for the return of products to customers.

Copyright Rhino Motion Controls, 2023 Neither the whole nor any part of the information contained in, or the product described in this manual, it may be adapted or reproduced in any material or electronic form without the prior written consent of the copyright holder. This product and its documentation are supplied on an as-is basis, and there is no warranty as to their suitability for any particular purpose is either made or implied. This document provides preliminary information that may be subject to change without notice.